

Tool Profiling Guidelines v1.5

Introduction

To cut pockets into shadow foam for tools, we need to capture certain information about the tool such as its details, profile and depth information.

A 2D profile is needed to cut the outline shape of the pocket and the depth information is needed to know how deep to cut the pocket. Quite often, more than one depth is required to ensure the tool sits level in the pocket.

What's Included

- This guide
- Lightbox
- Profiling Form



What's Involved

The Lightbox is used to capture the 2D silhouette of a tool which is used in turn to create an outline profile for the pocket in the foam.

The Profiling Form is used to capture details about the tool such as location, manufacturer, part number, description along with the lightbox id and the dimensional information.

The Lightbox cannot capture depth information of the tool and so this must be taken manually and captured on the Profiling Form.

The Lightbox does not need to be used to capture socket profiles or basic shapes (e.g. basic squares, rectangles or circles) as this can be determined by taking some dimensions and inputting them directly on the Profiling Form.

Information extracted from the lightbox along with the profiling form can be sent to Coplan to manufacture foam inlays as required with a perfect fit for your tools.

Lightbox

Lightbox Prerequisites

The Lightbox (v2) is approximately 540mm wide x 410mm deep x 1350mm tall. Whilst the lightbox is quite tall it can safely be placed on a desk. The Lightbox requires some assembly however no tools are required.

The Lightbox requires two power sockets, one for the light panel and one for the controller.

The Lightbox requires a laptop that has a wireless network adaptor, USB socket, a Web Browser (Microsoft Edge or Google Chrome) and Microsoft Excel.

The Lightbox controller has a built-in web server and wireless access point which you will need to directly connect to with a laptop to operate the lightbox.

The laptop will also be used to download the profiles (zip file) from the Lightbox that will later be sent to Coplan via email.

The laptop will require a USB socket and a USB memory stick to save the profiles onto for later transfer to another computer with access to email.

Note: The Lightbox does not directly connect to the internet.

Lightbox Setup

Assemble the lightbox (see separate guide).

Connect the power cables for the controller and light panel.

The controller will power up automatically when plugged in.

Switch the light panel on using the button on the left of the panel. Please note that the panel has 3 brightness levels and level 1 (the dimmest level) is required for profiling tools.

Connect the Laptop wireless network adaptor to the Lightbox. The Lightbox has a default SSID of **coplan-lightbox-mobileX** where X is the end number of the Lightbox Serial Number.

For example, if your serial number is CML002 then the SSID will be coplan-lightbox-mobile**2**.

The password for the wireless connection is '**coplanlightbox**'.

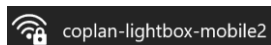

Once connected, open a web browser and enter the following URL: <http://192.168.50.1>.

You should be presented with the Lightbox home page:

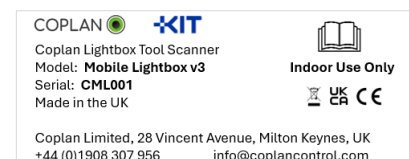

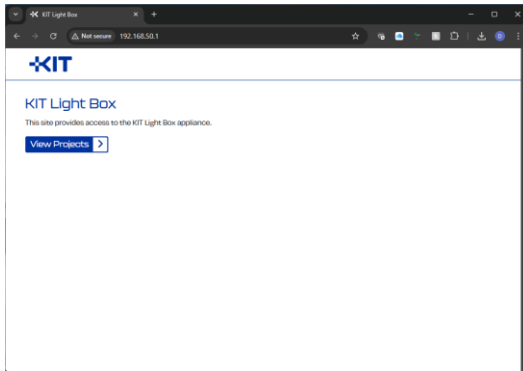

Structuring Projects

The following sections talk through how to use the Lightbox Projects and Profiling Forms to best organise and structure the data you will capture.

The Lightbox stores profiles in its local memory that can later be extracted to a zip file. Each profile captured is given a unique ID. The Lightbox application has a basic folder structure allowing you to store profiles against specific Projects.

The Profiling form is used to capture details about each tool such as location, manufacturer, part number, description along with the lightbox ID and the associated dimensional information.

Once a set of tools is profiled, the Profiles can be extracted from the Lightbox and emailed to Coplan along with the associated Profiling Form.

As a rule, it's best to structure your data per drawer or per location or per set of tools to keep the data aligned, the size of the files small and will be easier to collate.

This means creating a Lightbox Project and saving a copy of the Profiling Form per drawer or per location or per set of tools.

The next sections explain how to use the Lightbox Projects and the Profiling Form.

Lightbox Projects

When profiling tools, you will need to create or select a project. A project is simply a folder for managing a set of profiles and help to organise the files. Typically, a project name could a drawer, a location or a set of tools.

Adding a Project...

- From the web browser, select **View Project** to start.
- To add a new project, select the **Add new project** button, enter a suitable label and click **Save**.

Selecting an existing Project...

- To select an existing project, find the project in the list and select the **View** button.

NOTE: It is not currently possible to delete or rename projects or profiles!

Profiling Forms

The **CPL-96 Tool Loan and Profiling.xlsx** is an Excel file used to capture details about the tool such as location, manufacturer, part number, description along with the lightbox ID and the dimensional information. The form should be completed with as much information as possible.

There is a **Customer** tab for recording the customer and main project details.

Tool Control Tool Loan & Profiling Form - Tools	
v1.1 12/12/2024	
Customer Details	
Company Name	
Contact Name	
Project Name	
Quote Reference	
PO Number	
Tool Loan Details	
Date Tools Received	
Date Tools Returned	

There are a series of **General, Sockets, Screwdrivers** and **Rachets** tabs where we can record the details of the tools and profiling information.

Note: The reason for the separate tabs is to help organize data for different types of tools.

Project Details			Screwdriver Details				Profiling Details (Coplan only)						
Location Description	Quantity Required on Design	Manufacturer	Part Number	Description	Set Part Number (optional)	Notes	Quantity Received	Quantity Returned	Lightbox ID	Handle diameter D1 (mm)	Blade diameter D2 (mm)	Blade pocket depth (mm)	Comments

Please complete the **Project Details** section as this helps us understand where tools will be located and how many are needed in the foam inlay:

- **Location Description** is the drawer / location description to identify where the tools will be placed.
- **Quantity Required on Design** is the quantity of the specific tool to be incorporated into the inlay design(s).

Please complete the **Tool Details** section as this helps us understand what the tools are:

- **Manufacturer** is the manufacturer of the individual tool.
- **Part Number** is the part number of the individual tool.
- **Description** is the general description of the individual tool. For tools with different sizes, it's important to note the size.
- **Set Part Number** (optional) is the part number of the set that an individual tool belongs to where relevant.
- **NOTE:** We can use this information to also determine if we have tool information already in our library.

Please complete the **Profile Details** section after profiling each tool. See the next section for details.

Profiling Guidelines

Profiling a tool

Step 1...

- Start by adding an entry for the tool in the **Profiling Form**.
- **Note:** There are a series of **General, Sockets, Screwdrivers** and **Rachets** tabs where we can record the details of the tools and profiling information. The reason for the different tabs is to guide you on what dimensions are needs for different types of tools.
- Add details of the **Location, Quantity, Manufacturer, Part Number** and **Description**.

Step 2...

- From the web browser, select **Capture New Tools** to start the profiling process.
- You will see a live feed from the camera.
- Open the Lightbox door and carefully place the tool centrally on the light panel.
- **Note:** Please refer to the **Generals Notes on Profiling** section for details on how to prepare tools for profiling and what side of the tool needs to be profiled.
- **Note:** It is important to close the Lightbox door when capturing the profile to ensure there are no reflections on the surface of the tool from external light sources, which can cause the profile to be inaccurate.
- When you are happy with the tool position, close the Lightbox door and select **Take Photo**.
- The Lightbox will take a photo of the tool and produce a traced profile of the tool.

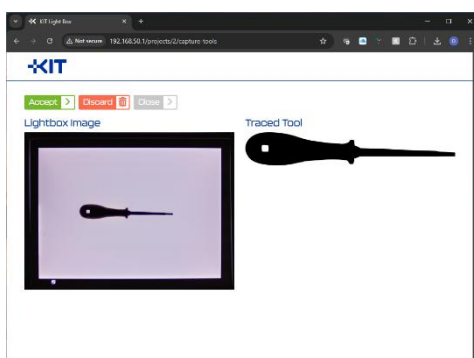

If you are happy with the profile, select **Accept** and this will be saved to the project.

If you are not happy with the profile, select **Discard** and repeat the process above.

- Each tool profile captured will have a unique ID number assigned.

Last image added with Id: 41

- The ID of the tool profile just captured will be shown on the screen which must be entered into the **Profiling Form** in the appropriate **Lightbox ID** column against the related tool. This allows us to match up the profile with the tool details and depth information.
- Remove the tool from the Lightbox.

Step 3...

- Additional dimensions must now be taken for the given tool and entered into the **Profiling Form**.
- **Note:** Please refer to the **Generals Notes on Profiling** section for details on how to prepare tools for profiling and what side of the tool need to be profiled.

Step 4...

- Once a tool has been profiled and dimensions taken, the Lightbox is ready to profile the next tool.
- Repeat the process for each tool.
- Once profiling is complete for the drawer, location or set of tools, select the **Close** button to return to the list of profiles captured and follow the **Preparing Data to Send to Coplan** section.

Generals Notes on Profiling

Please refer to the **sections below** for details on how to profile the tools and any additional measurements that need to be recorded in the **CPL-96 Tool Loan and Profiling Form**.

Tool Placement on the Light Panel

Please place the tool in the centre of the light panel.

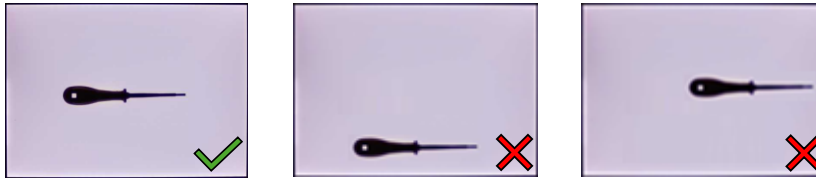

Tool Alignment on the Light Panel

Where possible, try and keep the tools parallel with the sides of the light panel.



Printing Face Up

Where possible, ensure any printing on a tool is facing upwards so visible when located in the foam inlay pocket. This could be the manufacturers logo or part number or more importantly the size of the tool. This is so that tools don't need to be removed to view any markings.

Oversized Tools

When profiling a tool that does not fit on the lightbox, profile the tool in two or more sections and note all the Lightbox IDs.

To do this...

- Open the Lightbox door and turn the Light panel brightness to the level 3 (brightest level).
- Place the first half of the tool on the light panel.
- **Note:** Please ensure there is enough overlap with distinguishing shapes/features to joins the profiles together at a later stage.
- **Note:** Where there are no distinguishing shapes/features, add a blob of Bluetack to the side of the object to create a distinguishing feature and ensure the two profiles include the Bluetack. The Bluetack profile will be removed when the profile is tidied.

- When you are happy with the tool position, close the door as much as possible and select **Take Photo**.
- Note the first lightbox ID in the **Profiling Form**.
- Open the Lightbox door and rotate the tool with the second half of the tool on the Light panel.
- **Note:** Please ensure the tool remains in the same orientation!
- When you are happy with the tool position, close the door as much as possible and select **Take Photo**.
- Note the second lightbox ID in the **Profiling Form**.

Once you have completed profiling an oversized tool, you need to return the Light panel brightness back to level 1 (the dimmest level). To do this, press and hold the Light panel button for at least 5 seconds to switch the panel off. Release the button and press once to switch the Light panel back on to brightness level 1 (the dimmest level).

If you are not sure, please contact Coplan for further advice.

Transparent Items

Transparent items cannot be profiled on the lightbox and should be measured. Please refer to the *Simple Shapes* section for measuring shaped items.

Dimension Accuracy

When capturing dimensions, please round up the measurements to the nearest whole number. E.g. round up 51.6 to 52.
Never round down!

Tools that have been profiled before

If you are aware that a tool has been profiled before and you know the Lightbox ID, there is no need to profile the tool again unless there is something different about the profile.

To reference a tool previously profiled, simply add the manufacture, part number, description and previous Lightbox ID to the Profiling Form.

Screwdrivers or T-Handles

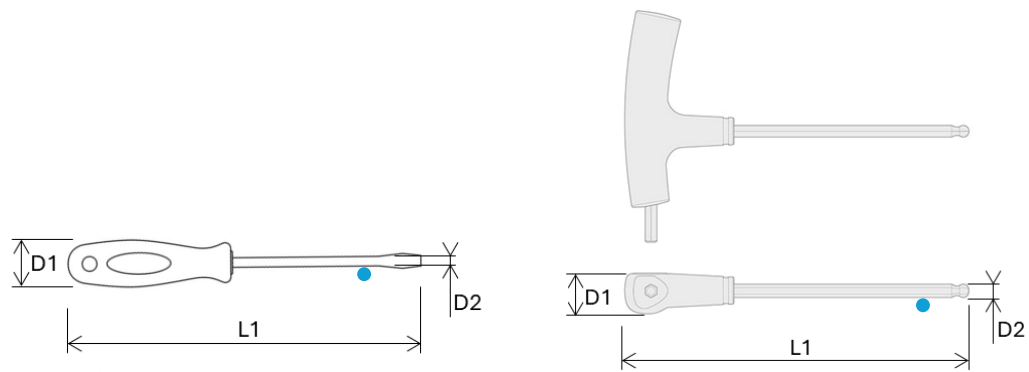

- Profile the screwdriver/T-handle with the label upwards where possible
 - **Note:** To get the best profile, ensure the blade is parallel with the light bed. If the screwdriver tilts towards the blade when placed on the lightbox, add a small blob of Blutack  under the blade to level it up
 - **Note:** For flat blade screwdrivers, ensure the flat blade is parallel with the light bed
- Record the Lightbox ID and dimensions below on the **Screwdrivers** tab of the Profiling Form:
 - Record largest diameter of the handle (D1)
 - Record largest diameter of the blade (D2)
 - **Note:** The depth of the blade pocket is calculated by $(D1 / 2) + (D2 / 2)$
 - **Note:** The blades on t-handles are typically the same diameter however if there are two different diameters, make a both.
 - Record the overall length (L1)

Spanners

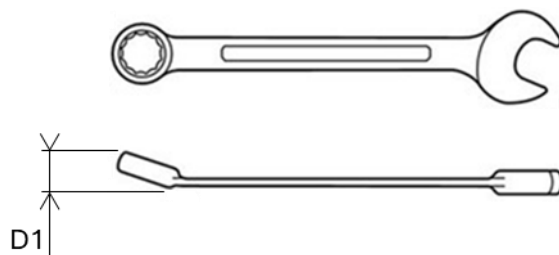

- Profile the spanner on its back with the size information on upwards
- Profile again with the spanner on its side.
- Record the Lightbox ID and dimensions below on the **General** tab of the Profiling Form:
 - Measure the depth D1

Sockets

NOTE: The measuring guide for sockets has changed since version 1.4 of the profiling guide. This now requires D1 to be the diameter of the attachment end and D2 to be the diameter of the socket end. This is to ensure all sockets generated are the same way around.

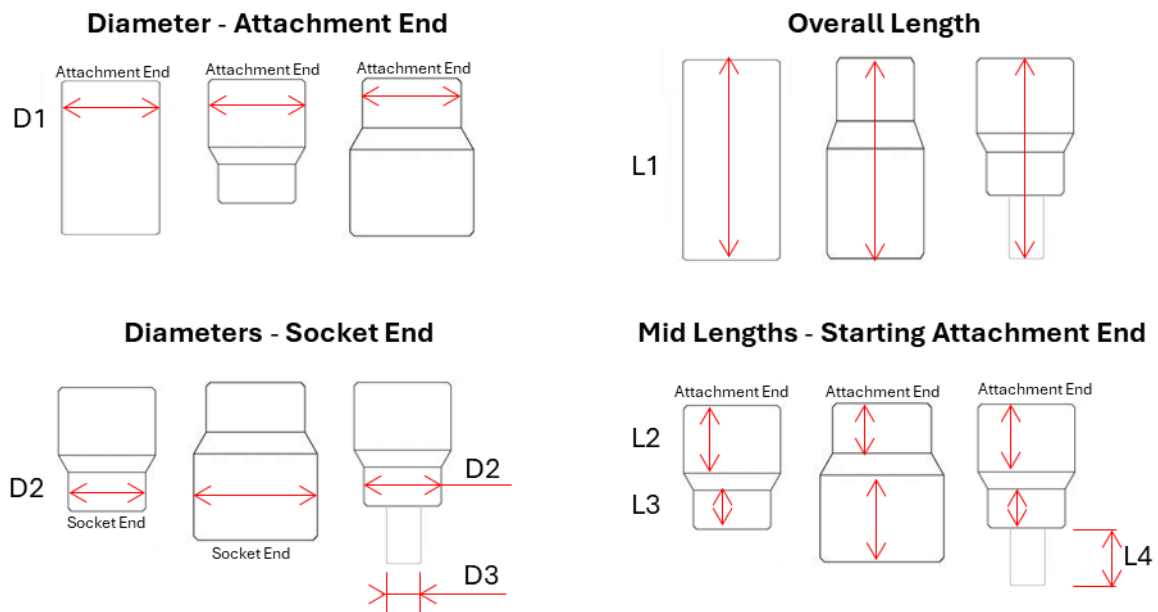

- There is no need to profile sockets on the lightbox however please record the following dimensions on the **Sockets** tab of the Profiling Form:
 - Record the **diameter of the attachment end (D1)**
 - Record the **overall length (L1)**
 - For shaped sockets:
 - Record the **diameter of the socket end (D2)**
 - Record the **length from the attachment end up to the chamfer (L2)**
 - Record the **length from the socket end up to the chamfer (L3)**
 - **Note:** The chamfer length will be calculated.
 - For sockets with additional attachments:
 - Record the **diameter of the socket attachments (D3)**
 - Record **the length of the socket attachments (L4)**

Pry-Bars

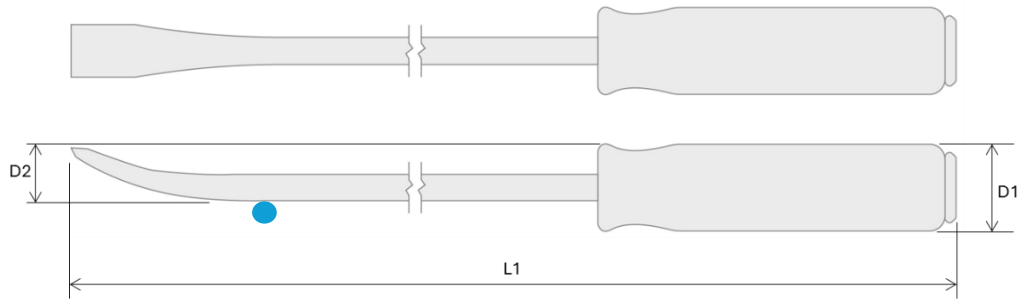

- Profile pry-bar lying flat with the blade pointing upwards
 - **Note:** To get the best profile, ensure the bar is parallel with the light bed. If the pry-bar tilts towards the blade when placed on the lightbox, add a small blob of **Blutack**  under the bar to level it up
- Record the Lightbox ID and dimensions below on the **General** tab of the Profiling Form:
 - Record largest depth of the handle (D1)
 - Record largest depth of the blade (D2)
 - Record the overall length (L1)

Rachets

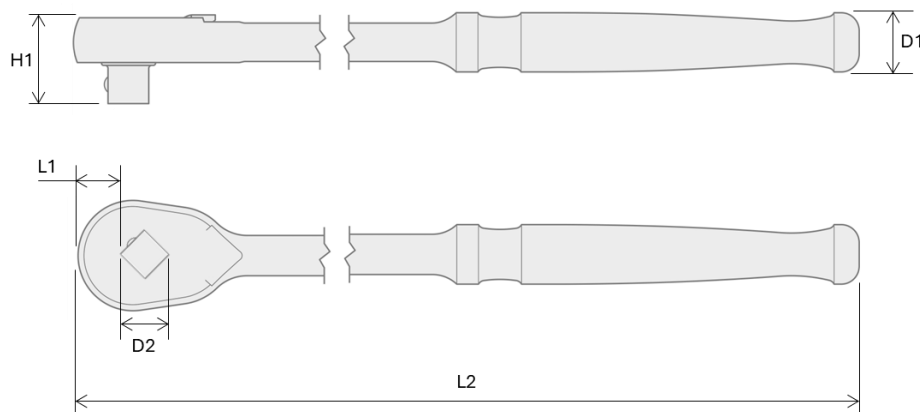

- Profile the rachets on its back with the attachment pointing upwards
- Record the Lightbox ID and dimensions below on the **Rachets** tab of the Profiling Form:
 - Record largest diameter of the handle (D1)
 - Record largest height of the attachment (H1)
 - Record distance between the end of the ratchet and the attachment (L1)
 - Record largest diameter of the attachment (D2)
 - **Note:** this must be across the diagonal to ensure we capture the largest possible diameter D2 and smallest distance L1
 - Record the overall length (L2)
- If profiling with an attachment, please ensure the largest possible attachment is profiled to ensure the pocket can accommodate the necessary attachments and measure H1, L1 and D2 dimensions with the largest attachment in place.

Hammers

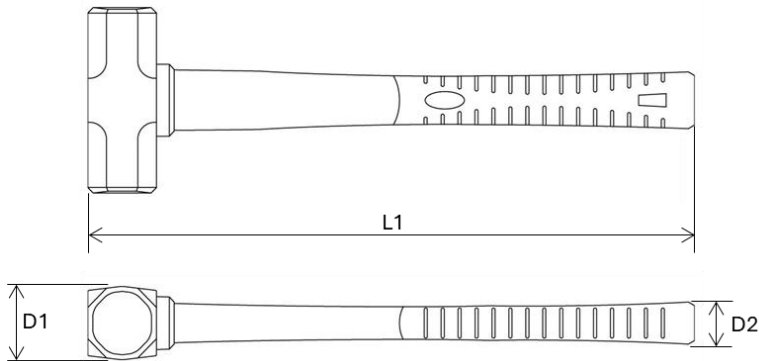

- Profile the hammer lying flat with the size information on upwards
- Record the Lightbox ID and dimensions below on the **General** tab of the Profiling Form:
 - Record largest depth on handle D1
 - Record depth of head D2
 - Record length L1 – this is to check for perspective distortion on larger hammers

Pliers

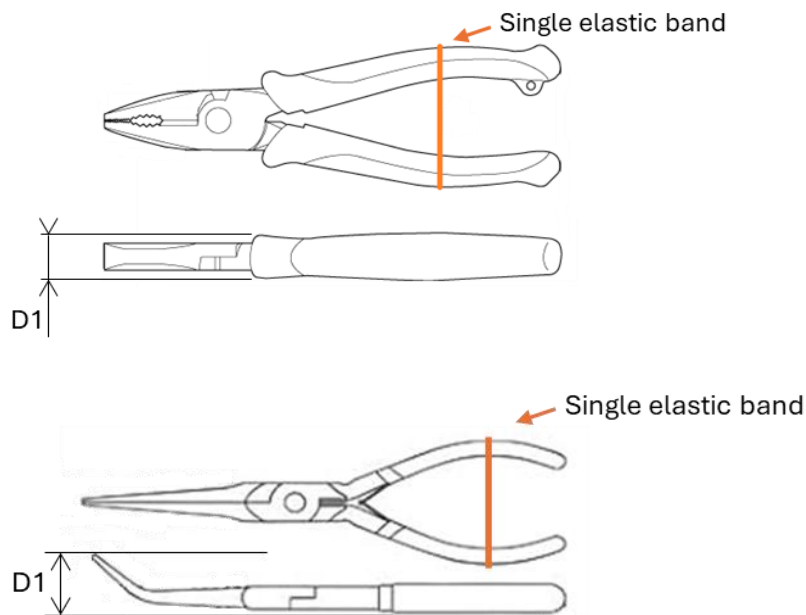

- Profile pliers lying flat with any size information on upwards
- Ensure pliers are profiled when closed – use a single rubber band to keep spring loaded pliers closed during profiling. The rubber band profile will be removed when the CAD file is cleaned up.
- Record the Lightbox ID and dimensions below on the **General** tab of the Profiling Form:
 - Record largest depth D1

Adjustable Wrench and Tube Wrench

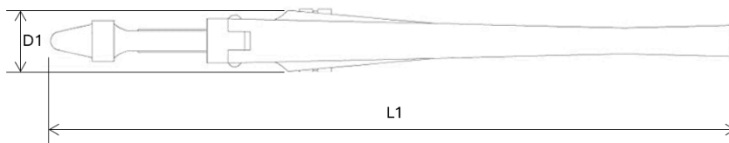
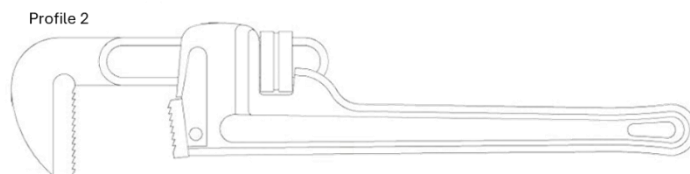
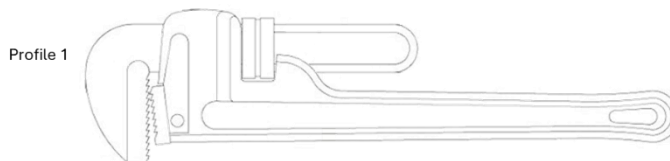
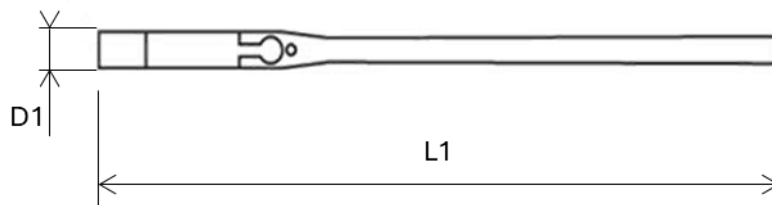
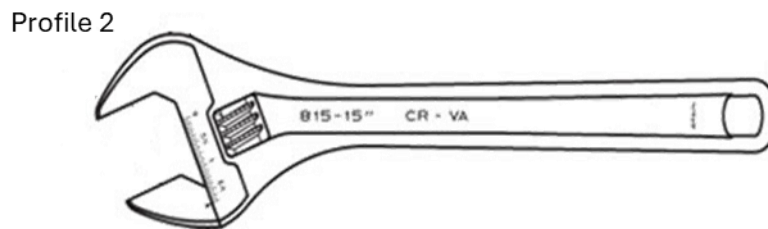
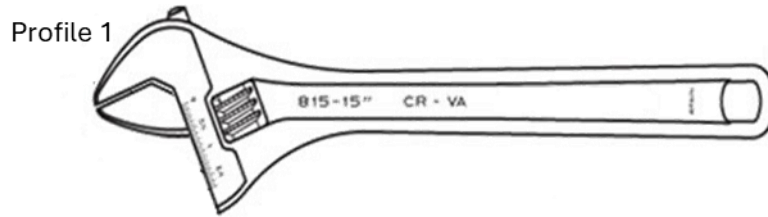

- Profile the adjustable wrench with the jaws fully closed
- Profile the adjustable wrench with the jaws fully opened
- Record the Lightbox ID and dimensions below on the **General** tab of the Profiling Form:
 - Record largest depth (D1)
 - Record the overall length (L1)

G-Clamps

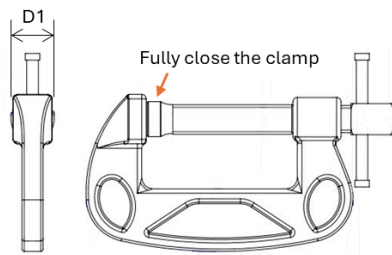

- Profile the G-Clamps with the jaws fully closed
 - **Note:** Do not profile them with the jaws open unless specifically asked for by the customer
- Record the Lightbox ID and dimensions below on the **General** tab of the Profiling Form:
 - Record largest depth D1

Hand Drills

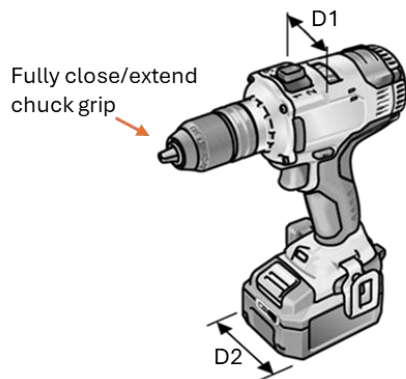

- Profile the Hand Drill with the Chuck Grip is fully closed/extended.
- Record the Lightbox ID and dimensions below on the **General** tab of the Profiling Form:
 - Record the largest depth of the main body of the power tool (D1)
 - Record the largest depth of the battery of power tool (D2)

Tape

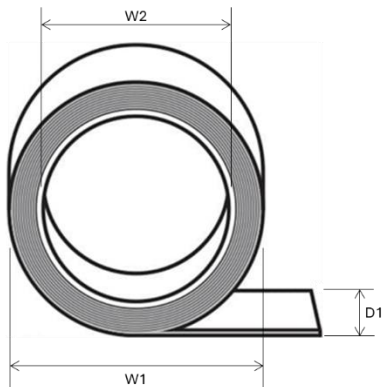

To produce a pocket that has a large enough diameter for a **full** roll of tape and have a peg in the centre of the pocket to keep the tape central, please take the following dimensions and record on the **General** tab of the Profiling Form:

- Record outer diameter of a **full** roll (W1)
- Record inner diameter of the roll (W2)
- Record the depth of the roll (D1)

Simple Shapes



- Record the dimensions below on the **General** tab of the Profiling Form:
 - For simple square or rectangular pockets, record the length, width and depth required.
 - For circular pockets, record the diameter (width) and depth required.

Preparing Data to Send to Coplan

Once you have profiled a Project, this data can be sent to Coplan via email for processing.

There are two files that need to be sent per Project...

1. The Profiling Form
2. The zip file exported from the Lightbox

Please email these files to info@coplancontrol.com.

Exporting the profiles from the Lightbox

- To access the list of profiles from the main screen, select **View Projects** and select the required project.
- To access the list of profiles from the profiling screen, select **Close**.

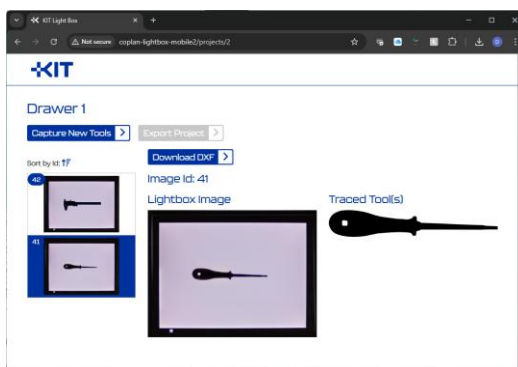

- To **export all the profiles** for the project, select the **Export Project** button.
- A zip file containing all the images and profiles will be downloaded to your browsers **Downloads** folder.
- **Note:** The file name will be Export-XXXXX.zip where XXXXX is the project name.
- **Note:** Some browsers may pop up a warning advising of an 'Insecure download blocked'. If this occurs, then select the Keep option to save the file.

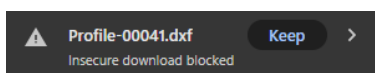

Coplan Notes

Lightbox URLs

The following URLs can be used whilst in the Coplan factory...

- Factory Lightbox: <http://coplan-lightbox/> or <http://192.168.1.180>

Lightbox Projects

When creating a project in the lightbox for a customer, name the project as either quote reference (preferred) or the name of the project on Monday.com so it's easy to cross-reference the profiles captured with the specific project.

Checking In Loaned Tools for Profiling

When tools are delivered to Coplan for profiling, the tools must be checked in to ensure we have a record of what tools have been received.

If the customer has completed the **CPL-96 Tool Loan and Profiling Form**, then the tools can be cross referenced and checked in on the form by completing the **Quantity Received** column.

Checking Out Loaned Tools after Profiling

When tools have been profiled and are ready to be returned to the customer, the tools must be checked out to ensure we returned all the tool that we have previously received. The tools can be cross referenced and checked out on the form by completing the **Quantity Returned** column.